

43'
TankMaster
Hi-Lo
Ready

Run. . .with the Best



3rd & Oak Streets
P.O. Box 388
Berwick, PA 18603
Tel 844-205-5525

www.cheetahchassis.com

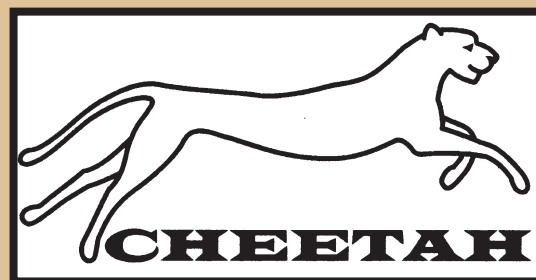

43' TankMaster Hi-Lo Ready

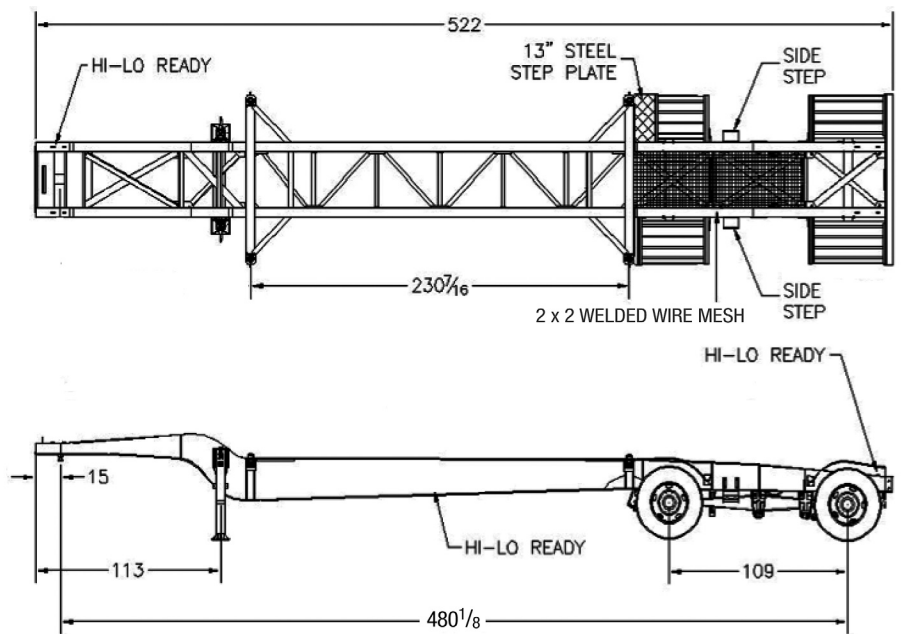

Function:

Carries one 20' ISO Tank Container. Meets all DOT and FMVSS regulations in effect at the time of manufacture and applicable to operation in the United States. When fitted with Hi-Lo kit (sold separately), carries two empty 20' ISO Tank Containers.

Standard Specifications

Hi-Lo: Hi-Lo kit ready. (Kit sold separately)

Overall Length: 43' 6".

Overall Width: 96" over tires.

Frame Height at Container: Approximately 45" at front, 44" at rear.

Kingpin Location: 15" from front of chassis.

Fifth Wheel Height: 47".

Beams: Fabricated grade 130 I-Beams tapered at rear.

Upper Coupler Assembly: 5/16" thick pick up plate. extends approximately 18" behind the kingpin with formed channels supports.

Bolsters: Fabricated channel.

Twist Locks: Meets ISO standards and requirements.

Lift Device: Lift ready. (Kit sold separately)

Rear Step: Mounted between axles, both sides.

Fenders: Aluminum, over both trailer rear axles. None at front of chassis.

Deck: 2" x 2" x 110" welded wire mesh.

Bumper: None.

Landing Gear: 55,000 lbs. lift, 160,000 lbs. static load capacity. 10 x 10 low profile sand shoes. Road side crank handle.

Axles: Two 22,500 lbs., 23,000 lbs. brake lining, tapered spindles, located 81 3/8" from the rear.

Suspension: Spread tandem, three leaf 24K HD springs, 109" axle spacing.

Hub and Drum: Steel hub piloted hub, outboard mounted drum. Synthetic Grease lubrication with seals.

Rims/Wheel: Steel 8.25 X 22.5 hub piloted tubeless painted white

Tires: IIR 22.5, 14 PLY.

Tire Inflation System: None.

Brake System: 2SIM, auto slacks, 30/30 brake chambers.

Hubdrometer: None.

Electrical System: 12 volt, 7-way split pin receptacle plug; modular wiring harness, flange mounted LED lights.

Metal Preparation: Clean, dry steel and NACE No. 3 /SSPC-SP-6 "Commercial Blast Cleaning". 70 % Zinc rich primer, urethane top coat.

Color: Ultra Marine Blue RAL 5002.

Customer Decals: None.

Conspicuity: Meets DOT requirements.

Registration / Card Holder: Plastic with clear screw-on cover.

Mud Flaps: 18" x 24" white plastic with Cheetah Logo. 4 hole mounting.

Steel & Fasteners: All structural steel is ASTM-A572, Grade 50, or ASTM-A607, Grade 50 or better. All structural fasteners are Grade 5 or better and are zinc coated.

GVWR: 80,000 lbs.

GAWR: 22,500 lbs. with tires rated at 5,625 lb. or higher.

Weight: Approximately 7,300 lbs. With Hi-Lo kit installed add 855 lbs. With Lift kit installed add 243 lbs.

Run...
with the Best

JOHN FULENWIDER, RSM

Cell: (972) 978-7120

Email: jfulenwider@cheetahchassis.com

Specifications subject to constant engineering design improvements.